

6M21

PowerKit Natural Gas Engine

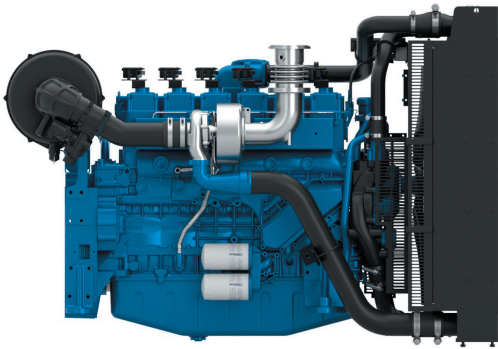

Bore x Stroke (mm)	127 x 156
Displacement (L)	12.54
N° of Cylinders	6
Cylinders Arrangement	In line
Fuel System	Open Chamber / Lean Burn
Governor (Gov.)	ECU
Aspiration (Asp.)	T/A-A

Customer benefits

Low emission standard, lean burn technology resulting in lower NOx emissions
 High transient and block load capabilities
 Full duty cycle capability, from prime to continuous power
 Low energy fuel capability (landfill & biogas)
 Electronically controlled high efficiency engines

Gas Engine		Gross Engine Output		Typical Generator Output				Asp	Gov
Model	Speed Rpm	COP Power kWm	PRP Power kWm	COP Power		PRP Power			
				kWe	kVA	kWe	kVA		
6M21G4N0/5	1500	245	288	204	255	240	300	T/A-A	ECU
6M21G4N0/6	1800	245	288	190	238	240	300	T/A-A	ECU

Aspiration : T/A-A = Turbocharged & Air-to-Air Aftercooled

Standard equipment

Engine and block

Cast iron frame style body structure
 One-piece forged crankshaft
 Split-cap forged steel connecting rods
 Separate cast iron cylinder heads with 4 valves
 Replaceable dry cylinder liners
 Aluminum alloy pistons with oil cooling gallery.

Cooling system

Radiator and hoses supplied separately
 Thermostatically-controlled system with belt driven coolant pump and pusher fan

Lubrication system

Flat bottom large capacity oil pan
 Spin-on full-flow lube oil filter

Fuel system

Mid-position and below inlet turbocharger optimized for genset application
 Special rear mounted air filter with restriction indicator
 Exhaust manifold shield for heat isolating

Air intake and exhaust system

Mid-position and below inlet turbocharger optimized for genset application
 Special rear mounted air filter with restriction indicator
 Exhaust manifold shield for heat isolating

Electrical system

12V DC electric starter motor and battery charging alternator for 1500 and 1800 RPM engines
 Low oil pressure & high water temperature sensors

Flywheel and housing

SAE 1 flywheel housing and 14" flywheel

Dimensions and dry weight (mm/kg)

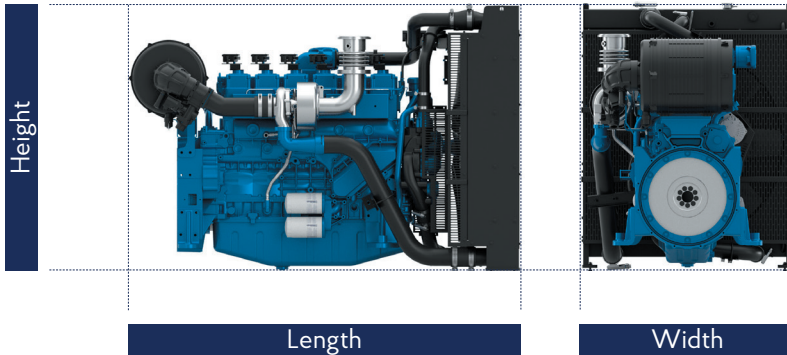

Diesel Engine		Dimensions and dry weights including radiator			
Model	Model	L (mm)	W (mm)	H (mm)	Weight (Kg)
6M16G4N0/5	1500	2034	1105	1385	977
6M16G4N0/6	1800	2034	1105	1385	977

Ratings definitions

Continuous Power (COP)

Continuous Power is the maximum power available for an unlimited period of use at a constant load factor. No overload capability is allowed.

Unlimited Prime Rated Power (PRP)

Prime Power is the maximum power available for unlimited hours of usage in a variable load application. The average load factor should not exceed 70% of the engine's PRP power rating during any 24 hour period. An overload capability of 10% is available, however, this is limited to 1 hour within every 12 hour period.

- 1) All ratings are based on operating conditions under ISO 8528-1, ISO 3046, DIN6271. Performance tolerance of $\pm 5\%$.
- 2) Test conditions: 100 kPa, 25°C air inlet temperature, relative humidity of 30%, with fuel density 0.84 kg/L. Derating may be required for conditions outside these; please contact the factory for details.
- 3) Power output curves are based on the engine operating with fuel system, water pump and lubricating oil pump; not included are battery charging alternator, fan and optional equipment.